

## AUDIOTAPE IN 12,5" MONOBOXES

### Packaging of reels (pancakes)

- |    |  |                |
|----|--|----------------|
| 1  | 12,5" monobox with two carton layers                   | 343x343x149 mm |
| 2  | PE layer   | Ø 320x2,0 mm   |
| 3  | PP layer   | 325x325 mm     |
| 4  | 15x2 pancakes of tape length (L):                      |                |
|    | 3750 m (AT-18)   | Ø 284 mm       |
|    | 5275 m (AT-12)   | Ø 320 mm       |
|    | 3535 m (AT-12)   | Ø 270 mm       |
|    | 5900 m (AT-11)   | Ø 323 mm       |
|    | 5275 m (AT-11)   | Ø 308 mm       |
|    | 3535 m (AT-11)   | Ø 260 mm       |
|    | 5275 m (AT-10 SW)                                      | Ø 300 mm       |
|    | 3535 m (AT-10 SW)                                      | Ø 254 mm       |
| 5  | Dustproof case   |                |
| 6  | Spline sleeve  | Ø 76,2x149 mm  |
|    | Monobox is shrink-wrapped in 60 micron film.           |                |
| 7  | Pallet   | 1145x960 mm    |
| 8  | Protection corner                                      | 60x60x1300 mm  |
| 9  | Carton layer for pallet                                | 1000x900 mm    |
|    | Transport pack is wrapped around in 23 micron PE film. |                |
| 10 | Space filler   |                |

### Pancake package layout

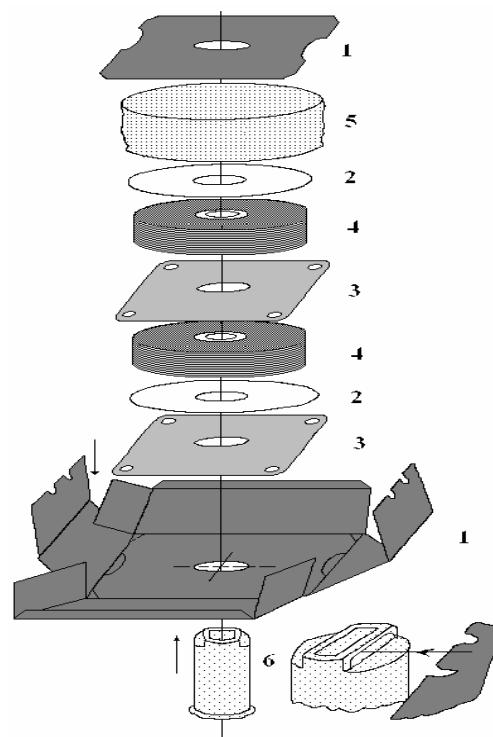

### Transport pack package layout

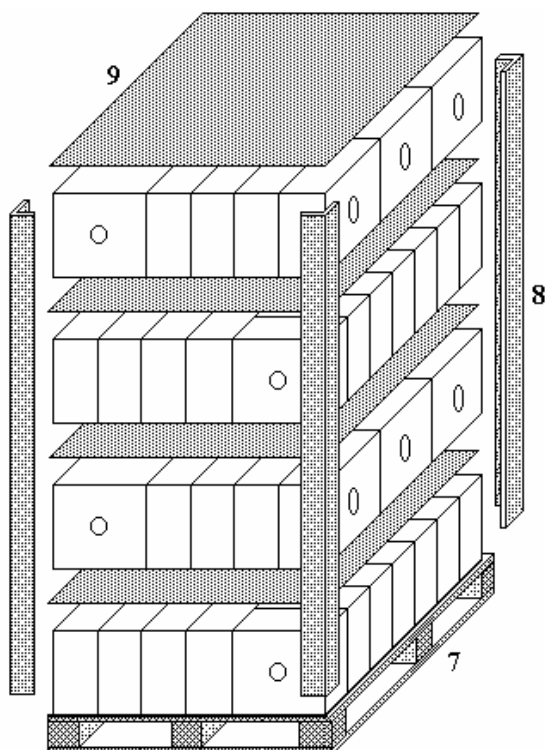

### Transport pack placement layout in 20-foot container

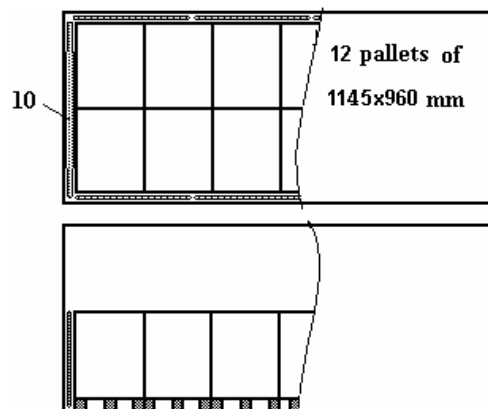

### Pancake tape quantity

- 1 reel – 22,479 m<sup>2</sup> (L=5900 m)
- 20,098 m<sup>2</sup> (L=5275 m)
- 14,288 m<sup>2</sup> (L=3750 m)
- 13,468 m<sup>2</sup> (L=3535 m)

### Number of pancakes

- On one pallet 1145x960 mm – 2280 pcs.
- 20-foot container (12 pallets) – 27360 pcs.
- 40-foot container (24 pallets) – 54720 pcs.

### Audio tape quantity on one pallet 1145x960 mm, gross weight

AT-18	-	994 kg	(L=3750 m)	AT-11	-	1032 kg	(L=5275 m)
AT-12	-	1140 kg	(L=5275 m)	AT-11	-	736 kg	(L=3535 m)
AT-12	-	806 kg	(L=3535 m)	AT-10 SW	-	959 kg	(L=5275 m)
AT-11	-	1138 kg	(L=5900 m)	AT-10 SW	-	687 kg	(L=3535 m)